

Receiver Blocking Resilience (RXBLR)

Bluetooth® Test Suite

- **Revision:** RXBLR.TS.p2
- **Revision Date:** 2025-02-28
- **Prepared By:** Regulatory Expert Group
- **Feedback Email:** gov-main@bluetooth.org
- **Published during TCRL:** Not applicable



Contents

1	Scope	3
2	References, definitions, and abbreviations	4
2.1	References	4
2.2	Definitions	5
2.3	Acronyms and abbreviations	5
3	Test Suite Structure (TSS)	7
3.1	Overview	7
3.1.1	Introduction to Bluetooth generations and Bluetooth Core Specification compliance	7
3.1.2	Performance criteria	8
3.1.3	Measurement setup	8
3.1.4	Interferer signal specifics	9
3.1.5	General Signaling Unit/Companion Device details	11
3.1.6	Receiver noise floor, signal-to-noise ratio, and sensitivity and wanted signal level	12
4	Test cases (TC)	13
4.1	Introduction	13
4.1.1	Test case identification conventions	13
4.2	Blocking Performance tests	13
	RXBLR/RF/FF/BV-11	14
	RXBLR/RF/FH/BV-11	14
	RXBLR/RF/FF/BV-12	14
	RXBLR/RF/FH/BV-12	14
	RXBLR/RF/FF/BV-13	14
	RXBLR/RF/FH/BV-13	14
	RXBLR/RFPHY/FF/BV-11	14
	RXBLR/RFPHY/FH/BV-11	14
	RXBLR/RFPHY/FF/BV-12	14
	RXBLR/RFPHY/FH/BV-12	14
	RXBLR/RFPHY/FF/BV-13	14
	RXBLR/RFPHY/FH/BV-13	14
5	Test case mapping	16
Appendix A Implementation Under Test (IUT) statement		17
A.1	IUT identification	17
A.2	Rx blocking resilience, IUT categorization list	17
Appendix B Measurement condition and setup documentation		21
B.1	Measurement conditions	21
B.2	Measurement setup documentation	21
Appendix C Receiver blocking resilience reporting format		22
C.1	RXBLR test data report format template	22
C.2	Example test data	25
6	Revision history and acknowledgments	26



1 Scope

This Bluetooth document contains the Test Suite to test the receiver blocking resilience of a Bluetooth implementation. Please note that this testing is intended to evaluate Bluetooth technology against the requirements defined in [ECC Recommendation \(24\)01, “Receiver resilience to transmission on adjacent frequency ranges”](#) [4].

To bridge to [4], this Test Suite document may use terminology that is from the ECC/ETSI domain rather than from the Bluetooth Special Interest Group (SIG). Some notable examples of this are as follows:

- BR/EDR corresponds to 1 MHz bandwidth 2.4 GHz WDTS in [4].
- LE1M/LE Coded corresponds to 1 MHz bandwidth 2.4 GHz WDTS in [4].
- LE2M corresponds to 2 MHz bandwidth 2.4 GHz WDTS in [4].
- The Rx Categorization (Cat. 1, Cat. 2, and Cat. 3) used in [4] comes from EN 300 328 [3], Section 4.2.3.2.
- The term Companion Device comes from EN 300 328 [3] and equates to what Bluetooth specifications typically refer to as a peer device to the IUT.

2 References, definitions, and abbreviations

2.1 References

This document incorporates provisions from other publications by dated or undated reference. These references are cited at the appropriate places in the text, and the publications are listed hereinafter.

- [1] Bluetooth Core Specification, Version 4.2 or later, Volume 0, Part D, Core Configurations
- [2] [Test Strategy and Terminology Overview](#)
- [3] [ETSI EN 300 328 V2.2.2 \(2019-07\)](#), “Wideband transmission systems; Data transmission equipment operating in the 2,4 GHz band; Harmonised Standard for access to radio spectrum”
- [4] [ECC Recommendation \(24\)01](#), “Receiver resilience to transmission on adjacent frequency ranges”
- [5] RFPHY Test Suite, LE Radio Physical Layer (RFPHY), Bluetooth Test Suite (from <https://www.bluetooth.com/specifications/specs/> under Core Specification v6.0)
- [6] RF Test Suite, BR/EDR Radio Physical Layer (RF), Bluetooth Test Suite (from <https://www.bluetooth.com/specifications/specs/> under Core Specification v6.0)
- [7] [SE21\(24\)014A01 Candidate_Golden_Waveform_above_1GHz_001](#), European Commission, Joint Research Centre (JRC)
- [8] [SE21\(24\)014A02 Characterization of Candidate_Golden_Waveform_above_1GHz_001](#), European Commission, Joint Research Centre (JRC)
- [9] [ECC Report 325](#) (for WAS/RLAN), “Compatibility and technical feasibility of coexistence studies for the potential introduction of new terrestrial applications operating in the 2483.5–2500 MHz frequency band with existing services / applications in the same band and adjacent bands”, ECC 23-04-2021
- [10] [Bluetooth Low Energy – Regulatory Aspects Document \(RAD\)](#) v1.01 or later, Bluetooth SIG
- [11] [CCITT Recommendation O.153](#) (1992), “Basic parameters for the measurement of error performance at bit rates below the primary rate”
- [12] [ITU-T Recommendation O.150](#) (1996), “General requirements for instrumentation for performance measurements on digital transmission equipment”
- [13] Updated Golden_Waveform_above_1GHz, Bluetooth SIG, “Updated wv-file for generation of the 5 MHz Reference Interferer” (available from <https://www.bluetooth.com/bluetooth-resources/receiver-blocking-resilience-testing/>)



2.2 Definitions

Term	Definition
Blocking	A measure of the receiver's capability to receive a wanted signal without exceeding a given degradation due to the presence of an unwanted signal at any frequency other than those of the spurious responses or of the adjacent channels; it is defined as the maximum interfering signal level expressed in dBm reducing the specified receiver sensitivity by a certain number of dBs (desensitization).
Frequency Offset Selectivity (FOS)	A measure of the receiver's ability to receive a wanted signal without exceeding a given degradation at its assigned channel frequency in the presence of an unwanted adjacent signal at a given frequency offset from the center frequency of the assigned channel. In this context, it is defined as the ratio of the receiver filter attenuation on the offset frequency to the receiver filter attenuation on the assigned channel frequency (normally a positive number in dB). FOS is of general use for any mixed wanted and unwanted signal situation.
Interference Leakage Ratio (ILR)	The ratio of the filtered mean power centered on the assigned channel frequency to the similarly filtered mean power centered on a given frequency offset.
Receiver desensitization (M)	Reduction in the signal-to-noise ratio of the receiver or a reduction in the effective sensitivity in the presence of an interfering signal, given in dB. It corresponds to the "noise rise" due to the interfering signal.
Receiver Interference Ratio (RIR)	The ratio of the in-channel interference power on a given frequency offset to the interference power received by the victim receiver.
Receiver noise floor (N)	The total noise power at the receiver, including the effect of thermal noise and the receiver noise figure.
Reciprocal spurious blocking domain (RSBD)	Implies that the victim receiver channel is in the spurious domain of the interfering transmitter and reciprocally that the interfering transmitter channel is in the spurious domain of the victim receiver.

Table 2.1: Definitions

Additionally, in this Bluetooth document, the definitions from [1] and [2] apply.

2.3 Acronyms and abbreviations

In this Bluetooth document, the definitions, acronyms, and abbreviations from [1], [2], [3], and [4] apply.

Acronyms and abbreviations	Definition
BER	Bit Error Rate
BR	(Bluetooth) Basic Rate 1 Mb/s. Commonly used in combination with EDR, as "BR/EDR" to describe the first generation of Bluetooth technology.
CW	Continuous Wave
EDR	(Bluetooth) Enhanced Data Rate 2 Mb/s for using $\pi/4$ -DQPSK (EDR2) and 3 Mb/s for EDR using 8DPSK modulation. Commonly used in combination with BR, as "BR/EDR" to describe the first generation of Bluetooth technology.
FER	Frame Error Rate
IUT	Implementation Under Test, a term used throughout this document to refer to the equipment/device that is subjected to testing.
KPI	Key Performance Indicator, representing a quantifiable metric



Acronyms and abbreviations	Definition
LE	(Bluetooth) Low Energy
LE 1M	Low Energy 1 Mb/s data rate
LE 2M	Low Energy 2 Mb/s data rate
LE Coded	Low Energy with coding gain for enhanced range; S=2 (2 symbols per bit) yields 500 kb/s data rate and can also be referred to as LE 500k, or S=8 (8 symbols per bit) yields 125 kb/s data rate and can also be referred to as LE 125k
PER	Packet Error Ratio
RI	Reference Interferer as defined in [4]
RXBLR	Receiver Blocking Resilience
SIG	Special Interest Group, used to describe the Bluetooth organization that oversees the development of Bluetooth standards and the licensing of the technology
SINR	Signal-to-Interference-plus-Noise Ratio
WDTS	Wideband Data Transmission Systems (herein with the meaning used by [3])

Table 2.2: Acronyms and abbreviations

3 Test Suite Structure (TSS)

3.1 Overview

This document provides the test cases for verification of the receiver's performance while operating in the presence of interference sources operating outside the 2400 to 2483.5 MHz band.

It has been defined to allow consistent testing to facilitate the collection of Bluetooth receiver performance for different receivers, while exposed to the two interferers referred to in [4], CW and 5 MHz Reference Interferer (RI). The 5 MHz RI uses the waveform provided in [13] (which is a header-corrected version of [7]). The specifics of the interferers are derived from [4] and described in Section 3.1.4, including the Lower Interferer and the Upper Interferer center frequencies.

The IUT receiver's performance is evaluated against performance criteria that are specific to the use cases defined by the manufacturer and that the IUT receiver is developed for. The IUT is tested during regular operation (frequency hopping) as well as when it is set to receive on fixed frequencies (this requires that the IUT be in test mode, which is enabled by, for example, custom test firmware). By performing the test at both a fixed frequency (adaptive frequency hopping disabled) and with adaptive frequency hopping enabled, the effectiveness of the normal Bluetooth operation can be determined.

Results obtained using this testing are expected to be reported to Bluetooth SIG, which anonymizes and aggregates the results for further analysis that eventually may be reported to the ECC WG SE.

When submitting test report data, please note that it is requested that the data is submitted in the format discussed in [Appendix C](#).

3.1.1 Introduction to Bluetooth generations and Bluetooth Core Specification compliance

Bluetooth technology has progressed through several generations, each characterized by distinct versions of the Bluetooth Core Specification. The first Bluetooth specification was published in 1999. The first generation of products used the PHY layer known as BR/EDR or Bluetooth Classic. These capabilities have since been refined in a series of updates and can be supported on their own or together with Bluetooth Low Energy (when used together, referred to as a dual-mode device). A device that supports BR/EDR, if designed today, will be compliant to Bluetooth v6.0 or earlier specifications back to Bluetooth v4.2.

In 2010, Bluetooth Low Energy (Bluetooth v4) was introduced and has since been a hotbed for innovation and development of short-range wireless connectivity. Bluetooth v5 and v6 are developments mainly of the Low Energy (LE) parts of the specification but also include maintenance of the BR/EDR.

A device that supports LE 1M PHY, if designed today, will be Bluetooth v4.2 or later compliant. An implementation supporting LE 2M PHY or LE Coded PHY, if designed today, will be Bluetooth v5.0 and later compliant. A device supporting Channel Sounding will be Bluetooth v6.0 and later compliant.

A Bluetooth LE audio device will be Bluetooth v5.2 or later compliant. Auracast™ is a set of Bluetooth-labeled LE audio features for broadcast audio, enabling seamless audio sharing and enhanced listening experiences.

A Bluetooth LE device that supports Channel Sounding for a distance awareness use case will be Bluetooth v6.0 or later compliant.

As Bluetooth continues to be a hotbed of innovation and development of short-range wireless connectivity, it is important to understand the regulatory requirements for bringing these unlicensed products to market. The Regulatory Aspects Document [10] provides descriptions of the different modes of LE operation and supporting information on RF regulations that apply in various geographic regions,



making it a valuable resource for anyone seeking to further understand Bluetooth technology or to be involved in product development.

3.1.2 Performance criteria

The tests within this document use the performance criteria defined in EN 300 328 [3] for receiver blocking. The criteria for evaluating performance of the IUT focus on its ability to maintain robust wireless communication in the presence of interference.

Before performing the tests, manufacturers must define the performance criteria for their tested receiver based on its intended use and must complete the form supplied in Appendix A.

Please observe the following principles when considering IUT-specific performance criteria:

- Tests within this document should be using a PER value to allow for comparable results between different tested Bluetooth IUTs.
- The default minimum performance criterion in [3] is for PER (or FER) to be $\leq 10\%$.
- When the minimum performance criterion in [3] is not applicable to the intended use, the performance criterion is defined by the manufacturer based on the intended use of the IUT, ensuring no loss of the wireless transmission function.

If the IUT can be configured to operate with different data rates, then the typical data rate and duty cycle needed for the intended use cases should be used (note that it does not require that the most demanding situation is tested). For example, in the case of a receiver used for A2DP for audio streaming, it may be tested at EDR2 (2-DH1, 2-DH3, or 2-DH5) rather than EDR3 (3-DH1, 3-DH3, or 3-DH5).

3.1.3 Measurement setup

The test setup to perform the conducted tests is shown in Figure 3.1. Please note that when testing an IUT, the specifics outlined in Appendix B need to be supplied together with the IUT details logged as outlined in Appendix A when providing the test results to the Bluetooth SIG.

If an IUT has multiple receive chains, then only one chain (primary antenna port) needs to be tested. All other receiver inputs are terminated.

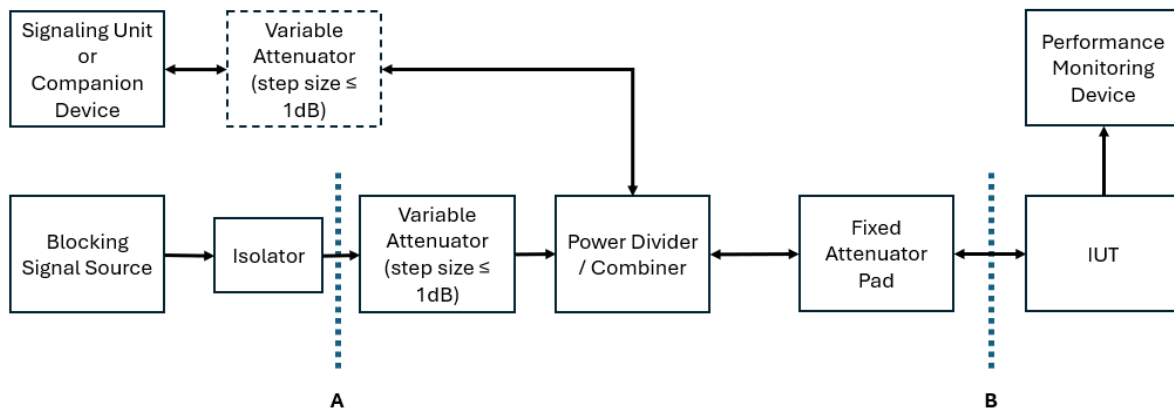

Figure 3.1: Test setup for receiver blocking

The Reference Interferer blocking signal is best generated at a fixed output power level and checked for compliance with the ECC Report (24)01 [4] spectral mask using a spectrum analyzer at the measurement plane labeled 'A' in Figure 3.1. Using a high isolation power combiner (for example, a Marki Microwave PBR-0003), there should be negligible levels of the output signal from the Signaling Unit/Companion Device present at the Blocking Signal Source output and vice versa. This will prevent the creation of

additional unwanted spectral content in the blocking test signal, due to intermodulation distortion effects in the output stages of the two signal generators, at location 'B'. Due to its non-reciprocal behavior, the isolator placed following the Blocking Signal Source acts as an additional attenuator to signals from the IUT that travel toward the output of the Blocking Signal Source. This removes them as a potential source of intermodulation distortion due to mixing in the output stage of the Blocking Source, which could corrupt the blocking test signal spectrum. An isolator is not placed in the Signaling Unit/Companion Device arm, as this would attenuate the wanted return signal from the IUT and could compromise the two-way connection required along this path between the two devices.

Reduction in the actual output power of the blocking signal to the required blocking test value is achieved using a variable attenuator(s) with a step size of 1 dB or less at the Blocking Signal Source output. The variable attenuator can be expected to be linear in operation (no distortion effects), whereas direct adjustments blocking generator output power might lead to power-dependent changes in the resulting spectrum as distortion effects in the output stage amplifier could change as the power level input to it is adjusted.

Measurement plane 'B', input to the IUT, is the location at which the wanted signal strength and the blocking signal strength need to be known for testing. The fixed attenuator before Measurement plane 'B' should be 6 dB or less.

Due to the "cliff edge" response of the BER versus SINR curve, a 1 dB or finer resolution attenuator should be used following the blocking signal generator so that the onset of blocking can be more easily and precisely determined.

When testing receiver blocking, especially for high sensitivity (sub -95 dBm) chipsets, it is important to limit signal leakage between the Signaling Unit/Companion Device, the Blocking Signal Source, and the IUT. It is recommended that the Signaling Unit/Companion Device, the Blocking Signal Source, and the IUT are placed in individual RF-shielded enclosures and that double-shielded or semi-rigid RF coaxial cables are used for interconnections. When selecting RF coaxial connectors for the test setup on shielded enclosures, consider their leakage levels. For example, a precision N-type coaxial connector has a maximum RF signal leakage level of -90 dB, a "quality" SMA connector could have a maximum RF leakage level of -60 dB, and a micro-surface-mount RF connector might have even higher leakage.

3.1.4 Interferer signal specifics

Derived from Table 31 in [4], the interferer signal specifics are summarized for the CW interferer and the 5 MHz Reference Interferer defined in [7]. The frequency offset is the distance between the center frequency of the interferer and the lower (2400 MHz) or upper (2483.5 MHz) frequency edge of the 2.4 GHz band.

In other words, the Lower Interferer's center frequency is 2379.5 MHz with the CW interferer and 2377 MHz with a modulated OFDM interferer. Similarly, the Upper Interferer's center frequency is 2504 MHz with the CW interferer and 2506.5 MHz with a modulated OFDM interferer.

Interferer ID #	Interferer Tx type	Freq offset (MHz), as defined by Table 31 in [4]	Lower Interferer center frequency (MHz)	Upper Interferer center frequency (MHz)	I (dBm), in [4]
1	CW	≥ 20.5	2379.5	2504	-34
2	5 MHz RI as defined in [7]	≥ 23	2377	2506.5	-34

Table 3.1: Interferer signal specifics



3.1.4.1 5 MHz RI (Reference Interferer), signal specifics

During the development of REC 24(01) [4], the reproduction of a 5 MHz Reference Interferer was a significant effort that required multiple attempts by specialists in the field.

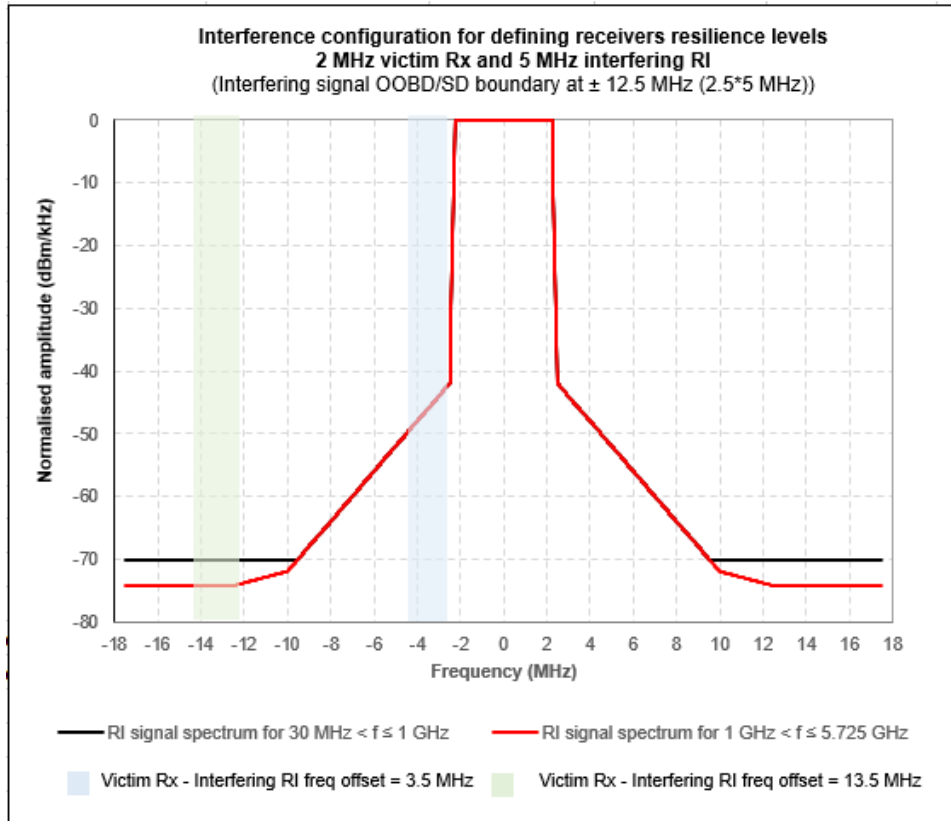

Figure 3.2: 5 MHz OFDM signal as described in REC 24(01) [4] Section A7.3.2

To reproduce the 5 MHz Reference Interferer used in REC 24(01) [4] with confidence, it is necessary to use the Golden Waveform for frequencies above 1 GHz referred to in [7] (Candidate_Golden_Waveform_above_1GHz_001.wv) by a signal generator.

In [4], Annex 8, two methods of generating the reference-interfering test signals are discussed. The first of the two methods, described in A8.1 of [4], relies on the Golden Waveform and is used for tests in this Test Suite.

Currently, there are two known signal generators, the **Rohde & Schwarz SMBV100A** and the **Rohde & Schwarz SMM100A**, that have been shown to reproduce the 5 MHz Reference Interferer sufficiently by using the Golden Waveform; for details, see the JRC test report [8]. Following the publication of this Bluetooth Test Suite, Rohde & Schwarz informed Bluetooth SIG that the SMBV100A is a discontinued product, which was replaced by SMBV100B. Rohde & Schwarz has advised that the SMBV100B offers the same RF performance as the SMBV100A for reproducing the 5 MHz Reference Interferer, making it a viable alternative.

In February 2025, while working with the wv-file from JRC, Bluetooth members discovered that it has an incorrect header, which can prevent some signal generators from generating the interferer signal. Once the Bluetooth SIG was made aware of the issue, a corrected wv-file was generated; for this reason, it is recommended that testing uses the updated Bluetooth wv-file [13] rather than the earlier version [7]. JRC has been made aware of the issue. Bluetooth SIG and JRC will convey the issue to CEPT next.

If other signal generators are used, it is important that the signal generator characterization of the waveform adheres similarly to the 5 MHz Reference Interferer as described in the JRC test report [8]. Bluetooth SIG members are encouraged to provide supplemental test reports showing that other signal generators also may be used in the test setup. In such a case, please consider the details in A8.1 in [4] and [8] when reporting the signal generator characterization of the waveform in other signal-generator equipment.

If a Bluetooth SIG member attempts to use other equipment but cannot achieve comparable performance with that equipment, then that member is encouraged to report this to the Bluetooth SIG to help gather data on equipment limitations that prevent its use in replicating the 5 MHz Reference Interferer.

3.1.5 General Signaling Unit/Companion Device details

The details of the pseudorandom sequence used by the Signaling Unit are described in Section 3.1.5.1, while Section 3.1.5.2 discusses what is expected while testing with a Companion Device.

3.1.5.1 Signaling Unit, using pseudorandom sequence (“PRBS9”)

In the fixed frequency test mode operation tests where the Signaling Unit is used instead of a Companion Device to evaluate the receiver, the same pseudorandom sequence of bits is used for each transmission (i.e., the packet is repeated). To do this, a PRBS9 sequence is used (see [11] and [12]). The PRBS9 pseudorandom sequence is chosen since it is a commonly used signal for receiver-type tests in Bluetooth Qualification testing of both BR/EDR (see [6]) and LE (see [5]) receivers.

The properties of this sequence are as follows (see also [12]). The sequence may be generated in a nine-stage shift register whose fifth and ninth stage outputs are XORed (see Figure 3.3), and the result is fed back to the input of the first stage. The sequence begins with the first ONE of nine consecutive ONES; i.e., the shift register is initialized with nine ones.

- Number of shift register stages: 9
- Length of pseudorandom sequence: $2^9 - 1 = 511$ bits
- Longest sequence of zeros: 8 (non-inverted signal)

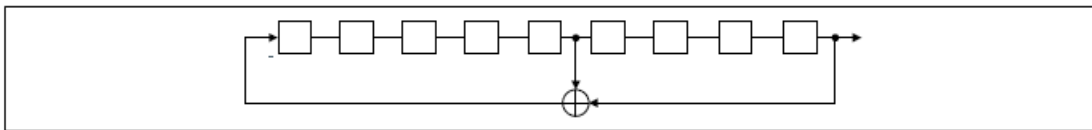

Figure 3.3: Linear feedback shift register for generation of the PRBS9 sequence

3.1.5.2 Companion Device details

This Test Suite assumes that there is a Companion Device used together with the IUT in normal operation mode. The Companion Device must be controllable enough to keep the IUT’s mode of operation stable during the test.

If the IUT is not a receive-only or a broadcast-only Bluetooth product, then it is possible to use the fact that the roles of the IUT and the Companion Device can be reversed, effectively also obtaining the receiver performance of what was the Companion Device in the first test run, but which takes the IUT role in the second run.

For example:

- First, test the receiver of an A2DP headset as the IUT, with an A2DP-capable mobile handset as the Companion Device.
- Second, test the receiver of the same A2DP-capable mobile handset as the IUT, with the A2DP headset as the Companion Device.
- Note that if testing the receiver performance of both devices is possible, then the results need to be recorded separately and accompanied by a completed form as outlined in [Appendix A](#), one for the A2DP headset and one for the A2DP-capable mobile handset.

3.1.6 Receiver noise floor, signal-to-noise ratio, and sensitivity and wanted signal level

[Table 3.2](#) is a Bluetooth-centric distillation of [Table 32](#) in [\[4\]](#). The data shown here is used to set levels needed to define the test conditions used during the tests.

Receiver parameter	BR/EDR and LE1M/ LECoded (1 MHz WDTS)			LE2M (2 MHz WDTS)			Comment
	Cat. 1	Cat. 2	Cat. 3	Cat. 1	Cat. 2	Cat. 3	
Channel BW (MHz)	1			2			
Effective BW (MHz)	1			2			
Noise figure NF (dB)	8	10	14	8	10	14	ECC Report 325 (for WAS/RLAN) [9] Typical values for 1 MHz and 2 MHz WDTS are displayed.
Noise power N (dBm)	-106	-104	-100	-103	-101	-97	According to Equation (3) in [4]
Sensitivity (Rx sens) (dB)	-91	-89	-85	-88	-86	-82	ECC Report 325 (for WAS/RLAN) [9]
Signal-to-noise ratio C/N (dB)	15	15	15	15	15	15	$Rx\ sens(dBm) - N(dBm)$
Wanted signal level C (dBm)	-73	-69	-59	-70	-66	-56	As defined in EN 300 328 [3] (-133 dBm + 10 × log ₁₀ (OCBW)) or -68 dBm, whichever is lower for Category 1 (-139 dBm + 10 × log ₁₀ (OCBW) + 10 dB) or -74 dBm + 10 dB, whichever is lower for Category 2 (-139 dBm + 10 × log ₁₀ (OCBW) + 20 dB) or -74 dBm + 20 dB, whichever is lower for Category 3

Table 3.2: Receiver noise floor, signal-to-noise ratio, and sensitivity and wanted signal level

4 Test cases (TC)

4.1 Introduction

4.1.1 Test case identification conventions

Test cases are assigned unique identifiers per the conventions in [2]. The convention used here is: **<cap abbreviation>/<IUT PHY test group>/<operation>/<nn>**.

Identifier Abbreviation	Capability Identifier <cap abbreviation>
RXBLR	Receiver Blocking Resilience
Identifier Abbreviation	Reference Identifier <IUT PHY test group>
RF	Radio Frequency (BR/EDR radio operation)
RFPHY	Radio Frequency Physical Layer (LE radio operation)
Identifier Abbreviation	Operational Mode Identifier <operation>
FF	Fixed Frequency (test mode operation)
FH	Frequency Hopping (normal Bluetooth operation)

Table 4.1: RX-EC Blocking TC feature naming conventions

4.2 Blocking Performance tests

- Test Purpose

These tests verify that the receiver performs satisfactorily in the presence of interference sources operating outside the 2400 to 2483.5 MHz band.

- Initial Condition

- Document the performance criteria (see Section 3.1.2) for the tests applicable to the IUT using the form found in Appendix A.
- Document the specifics of the IUT as outlined in Appendix A.
- Document the specifics of the test equipment used in the measurement setup as outlined in Appendix B.
- Conduct the measurements at normal environmental test conditions (Temperature within the range of +15° C to +35° C and Relative Humidity within the range 20% RH to 75% RH).
- All power levels in this test procedure are measured as RMS levels.
- Set the IUT operation mode to Fixed Frequency (FF) or Normal operation, frequency hopping mode as defined in Table 4.2.
- In the fixed frequency (FF) test group, the receiver operates on a static operating channel together with a Signaling Unit or companion Bluetooth device. When a Signaling Unit is used, it will transmit the PRBS9 bit sequence described in Section 3.1.5.1.
- In the frequency hopping (FH) test group, the receiver operates in the normal operation mode together with a companion Bluetooth device.

- Test Case Configuration

TCID	PHY exercised	IUT operation mode	Wanted signal, (see Table 3.2)
RXBLR/RF/FF/BV-11	BR/EDR RF Cat. 1	Fixed Frequency, test mode	-73
RXBLR/RF/FH/BV-11	BR/EDR RF Cat. 1	Normal operation, frequency hopping	-73
RXBLR/RF/FF/BV-12	BR/EDR RF Cat. 2	Fixed Frequency, test mode	-69
RXBLR/RF/FH/BV-12	BR/EDR RF Cat. 2	Normal operation, frequency hopping	-69
RXBLR/RF/FF/BV-13	BR/EDR RF Cat. 3	Fixed Frequency, test mode	-59
RXBLR/RF/FH/BV-13	BR/EDR RF Cat. 3	Normal operation, frequency hopping	-59
RXBLR/RFPHY/FF/BV-11	LE RFPHY Cat. 1	Fixed Frequency, test mode	-70
RXBLR/RFPHY/FH/BV-11	LE RFPHY Cat. 1	Normal operation, frequency hopping	-70
RXBLR/RFPHY/FF/BV-12	LE RFPHY Cat. 2	Fixed Frequency, test mode	-66
RXBLR/RFPHY/FH/BV-12	LE RFPHY Cat. 2	Normal operation, frequency hopping	-66
RXBLR/RFPHY/FF/BV-13	LE RFPHY Cat. 3	Fixed Frequency, test mode	-56
RXBLR/RFPHY/FH/BV-13	LE RFPHY Cat. 3	Normal operation, frequency hopping	-56

Table 4.2: RX Blocking Performance test cases

- Test Procedure

- For each of the Interferers in [Table 3.1](#), repeat Steps 2–11.
- If the IUT operation mode = Fixed Frequency, then set the IUT on its lowest operating channel and note the center frequency of the channel.
- Set the Blocking Signal Source center frequency to the Lower Interferer's center frequency for the applicable Interferer defined in [Table 3.1](#).
- With the Blocking Signal Source switched off, establish a communication link between the IUT and the associated Companion Device or the Signaling Unit using the test setup shown in [Figure 3.1](#). Use a wanted signal level at plane B of at least +10 dB above the expected Receiver Sensitivity to facilitate a reliable connection.
- Reduce the level of wanted signal level in 1 dB steps, when measured at the reference plane 'B' in [Figure 3.1](#), until the PER/BER fails over at least 200 packets (as defined by the Performance Criteria defined for the IUT, see Section 3.1.2), then increase the wanted signal level by +1 dB so that the PER/BER passes over at least 1000 packets. Record the RMS level as RxSen.
- Set the RMS power blocking level at the IUT to be the same level as RxSen for the applicable Interferer defined in [Table 3.1](#). Increase the blocker level in 1 dB steps until the PER/BER fails over at least 200 packets, then reduce the blocker level by 1 dB so that the PER/BER passes over at least 1000 packets; record the value of the blocker for the X axis and the value wanted for the Y axis of the performance graph.
- Reduce the RMS power blocker level by 10 dB, then increase the wanted signal by 1 dB. Increase the blocker signal until the PER/BER fails over at least 200 packets, then reduce the blocker level by 1 dB so that the PER/BER passes over at least 1000 packets, and record both levels as in Step 6.
- Repeat Steps 5–7 until the Blocking Signal Source is at a maximum or the level reaches -10 dBm.
- If the IUT operation mode = Fixed Frequency, then set the IUT on its highest operating channel and note the center frequency of the channel.
- Set the Blocking Signal Source center frequency to the Upper Interferer's center frequency for the applicable Interferer defined in [Table 3.1](#).
- Repeat Steps 4–8.



- Expected Outcome

Obtain the submitting test data in the requested report format discussed in [Appendix C](#).

[Figure 4.1](#) provides an example of the data that can be obtained during this test, illustrated graphically. In this example, the IUT's receiver sensitivity gradually degrades when exposed to increased power from the CW interferer and the 5 MHz Reference Interferer, as defined in [Table 3.1](#). The steps in receiver sensitivity degradation are artifacts of the IUT's automatic gain control function.

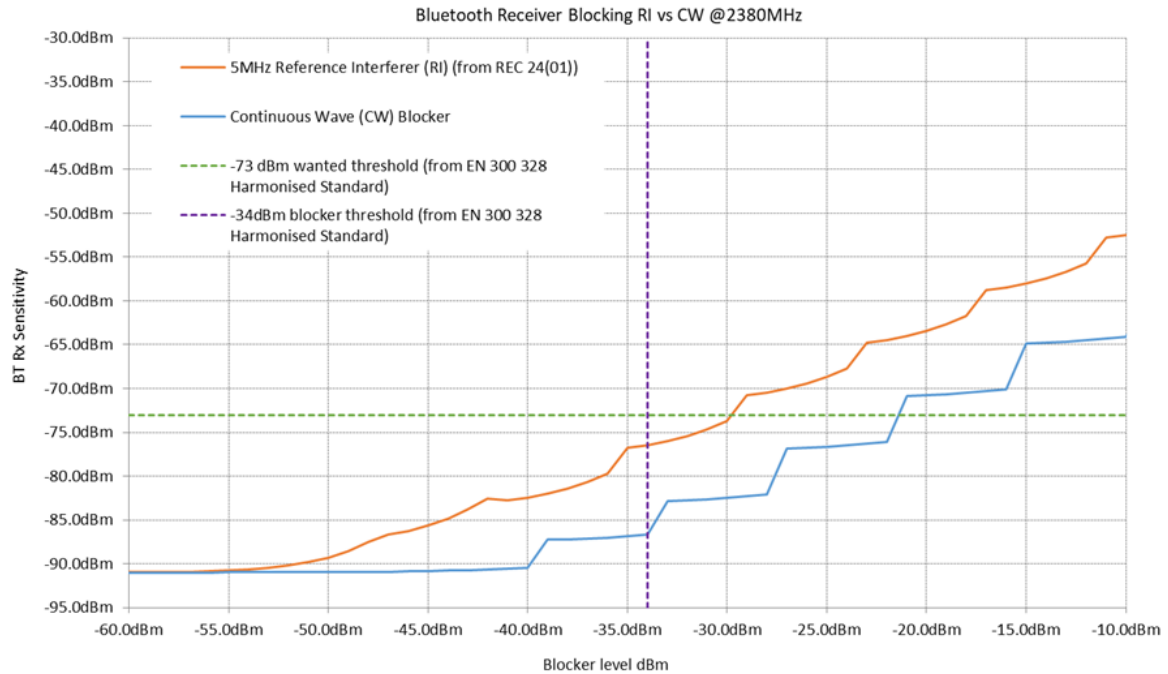

Figure 4.1: Example of the curves obtained while using the Interferers in [Table 3.1](#)

- Supplementary Notes

For additional information, see:

- [\[3\]](#) Section 4.2.3 for receiver category definitions; Section 5.4.11 for the EN 300 328 compliance test procedure on receiver blocking
- [\[5\]](#) Section 4.6.3 for blocking performance testing as defined for Bluetooth Qualification of the LE Physical Layer; Section 6.3 for supplementary discussion on packet error rate/bit error rate measurements when performed in Bluetooth Qualification testing
- [\[6\]](#) Section 4.6 for blocking performance testing as defined for qualification of the BR/EDR radio; Section 6.4 for supplementary discussion on bit error rate measurements when performed in Bluetooth Qualification testing

5 Test case mapping

The Test Case Mapping Table (TCMT) maps test cases to capabilities as outlined in [Appendix A](#).

With the tables from the appendix filled in, one gets the test cases to execute from [Table 5.1](#) for the supported IUT capabilities.

The columns for the TCMT are defined as follows:

Item: Contains a logical expression (using the operators AND, OR, NOT as needed) based on specific entries from [Appendix A](#). The entries are in the form of RXBLR y/x references, where y corresponds to the table number and x corresponds to the feature number as defined in [Appendix A](#).

Feature: A brief, informal description of the feature being tested.

Test Case(s): The applicable test case identifiers are required to be executed when the corresponding RXBLR y/x references from [Appendix A](#) are supported.

Item	Feature	Test Case(s)
RXBLR 1/1 AND (RXBLR 2/1 OR RXBLR 2/3)	BR/EDR Cat. 1 Rx performance	RXBLR/RF/FF/BV-11 RXBLR/RF/FH/BV-11
RXBLR 1/2 AND (RXBLR 2/1 OR RXBLR 2/3)	BR/EDR Cat. 2 Rx performance	RXBLR/RF/FF/BV-12 RXBLR/RF/FH/BV-12
RXBLR 1/3 AND (RXBLR 2/1 OR RXBLR 2/3)	BR/EDR Cat. 3 Rx performance	RXBLR/RF/FF/BV-13 RXBLR/RF/FH/BV-13
RXBLR 1/1 AND (RXBLR 2/2 OR RXBLR 2/3)	RFPHY Cat. 1 Rx performance	RXBLR/RFPHY/FF/BV-11 RXBLR/RFPHY/FH/BV-11
RXBLR 1/2 AND (RXBLR 2/2 OR RXBLR 2/3)	RFPHY Cat. 2 Rx performance	RXBLR/RFPHY/FF/BV-12 RXBLR/RFPHY/FH/BV-12
RXBLR 1/3 AND (RXBLR 2/2 OR RXBLR 2/3)	RFPHY Cat. 3 Rx performance	RXBLR/RFPHY/FF/BV-13 RXBLR/RFPHY/FH/BV-13

Table 5.1: Test case mapping

Appendix A Implementation Under Test (IUT) statement

The details in this appendix are captured to generate a test plan on the Rx blocking resilience tests to perform and to facilitate later analysis and reporting to the ECC WG SE. It must be filled in and supplied with test results gathered to verify the Rx blocking resilience performance of Bluetooth implementations.

A.1 IUT identification

Table 0: IUT Identification

IUT supplier	
IUT	
Applicable performance criteria (see Section 3.1.2)	

A.2 Rx blocking resilience, IUT categorization list

Table 1: WG SE Rx Categorization

Item	Category	Reference	Status	Support
1	BR/EDR Rx, Category 1 ¹	[4] Annex 6, Table 31	C.1	
2	BR/EDR Rx, Category 2 ²	[4] Annex 6, Table 31	C.1	
3	BR/EDR Rx, Category 3 ³	[4] Annex 6, Table 31	C.1	
4	LE Rx, Category 1 ¹	[4] Annex 6, Table 31	C.1	
5	LE Rx, Category 2 ²	[4] Annex 6, Table 31	C.1	
6	LE Rx, Category 3 ³	[4] Annex 6, Table 31	C.1	

C.1: At least one must be supported.

Note: In [4], the 1 MHz bandwidth 2.4 GHz WDTS classification corresponds to BR/EDR, LE1M/LE Coded operation; while 2 MHz bandwidth 2.4 GHz WDTS corresponds to LE 2M.

Table 2: Transports

Item	Functionality	Reference	Status	Support
1	Bluetooth BR/EDR	[1] 2	C.1	
2	Bluetooth LE	[1] 2	C.2	
3	Bluetooth Dual mode	[1] 2	C.3	

C.1: Should be supported IF at least one of RXBLR 1/1 OR RXBLR 1/2 OR RXBLR 1/3 is supported.

C.2: Should be supported IF at least one of RXBLR 1/4 OR RXBLR 1/5 OR RXBLR 1/6 is supported.

C.3: Should be supported IF at least one of RXBLR 1/1 OR RXBLR 1/2 OR RXBLR 1/3 is supported AND at least one of RXBLR 1/4 OR RXBLR 1/5 OR RXBLR 1/6 is supported.

¹ Cat. 1: as defined in [3], adaptive equipment with RF output power > 10 dBm e.i.r.p.

² Cat. 2: as defined in [3], equipment (adaptive or non-adaptive) with RF output power between 0 and 10 dBm e.i.r.p., or non-adaptive equipment with MU between 1% and 10%

³ Cat. 3: as defined in [3], equipment (adaptive or non-adaptive) with RF output power ≤ 0 dBm e.i.r.p., or non-adaptive equipment with MU ≤ 1%



Table 3: Bluetooth LE Functionality*Prerequisite: RXBLR 2/2 "Bluetooth LE" OR RXBLR 2/3 "Bluetooth Dual mode"*

Item	Functionality	Status	Support
1	LE 1M	M	
2	LE 2M	O	
3	LE Coded (S=2 coding/LE 500k or LE S=8 coding/LE 125k)	O	
4	Channel Sounding	O	

Table 4: Product Segment

Item	Segment	Status	Support
1	Bluetooth Chipset	C.1	
2	Bluetooth Module	C.1	
3	Bluetooth End Product design	C.1	

C.1: At least one must be supported.



Table 5: Device Categorization⁴

Item#	Category	Description	Status (indicate if the performance criteria used are applicable to the supported categorization)	Support
1	Audio Streaming			
1a	Wireless headset	Audio devices, from earphones to earbuds; essential mobile phone accessories for hands-free communication and quality audio		
1b	Wireless speakers	Audio-emitting devices ranging from home systems to portable options for outdoor use		
1c	In-car systems	In-car infotainment systems that pair with driver smartphones to enable hands-free audio streaming and calling		
1d	Hearing devices	Hearing aids and augmented assisted-listening devices		
2	Data transfer			
2a	Sports & Fitness	Bluetooth-enabled wearables such as fitness trackers and smartwatches, widely used for monitoring steps, exercise, activity, and sleep		
2b	PC Peripherals & Accessories	Wireless devices such as keyboards, trackpads, or mouse devices that connect to systems using Bluetooth technology		
2c	Health & Wellness	Bluetooth-enabled devices such as blood-pressure monitors and portable imaging systems, used for tracking health and aiding healthcare professionals in providing care		

⁴ Taken from Bluetooth SIG market research 2024



Item#	Category	Description	Status (indicate if the performance criteria used are applicable to the supported categorization)	Support
3	Location Services			
3a	Asset-tracking tags	Real-time locating system solutions for tracking objects and individuals, used in various settings such as warehouses and hospitals		
3b	Personal item-finding solutions	Tags are used with a smartphone application to locate misplaced personal items		
3c	Access-control systems	Systems where smartphones, enhanced with Bluetooth technology, serve as digital keys to unlock doors and space		
4	Device Networks			
4a	Smart home devices	Bluetooth technology-enabled gadgets that automate and control home environments, monitor energy, and enhance security		
4b	Networked-lighting control devices	Bluetooth systems used in various commercial facilities for energy savings, improved occupant experience, and efficient operations		
4c	Condition-monitoring systems	Bluetooth wireless sensor networks that track various parameters to enhance productivity, reduce costs, and minimize equipment downtime		
4d	Electronic Shelf Label systems	Bluetooth-enabled e-paper displays that automate pricing and inventory management at retail shelves		



Appendix B Measurement condition and setup documentation

Use the details in this appendix to document the specific conditions during test performance as well as the details of measurement setup used in testing, as described in Section 3.1.3.

B.1 Measurement conditions

Table 1: Measurement Conditions

Testing company		
Location of the test		
Environmental conditions at the time of testing:		
Test date (YYYY/MM/DD)		
Temperature (°C)		Normal environmental conditions: +15° C to +35° C
Humidity (%RH)		Normal environmental conditions: 20% RH to 75% RH

B.2 Measurement setup documentation

Table 2: Measurement Setup Documentation

Designation	Manufacturer	Model	Calibration date
Signal Source	1)	1)	1)
Companion Device	1)	1)	2)
Spectrum Analyzer	1)	1)	1)
Variable Attenuator #1	1)	1)	2)
Variable Attenuator #2	1)	1)	2)
Power Divider/Combiner	1)	1)	2)
Cable	1)	1)	N/A
Measurement Uncertainty (if known)			
	¹⁾ Details required to be added ²⁾ If applicable, add details		



Appendix C Receiver blocking resilience reporting format

When reporting test results to the Bluetooth SIG, please supply the results in the comma-separated value format for the exercised tests, as described by the RXBLR test data report format template below. A downloadable .txt version of the test data report format file can be found on the Bluetooth SIG website at: <https://www.bluetooth.com/bluetooth-resources/receiver-blocking-resilience-test-suite/>

C.1 RXBLR test data report format template

RXBLR.TS.p2 test data

! Comments are preceded by an exclamation mark (!).

! Text preceded by the hash symbol (#) identifies test specifics.

! See one example of test data in the end of this file.

<IUT Supplier Name>, <IUT>, <Applicable Performance Criteria - %PER>

<Test Case ID RXBLR/RF/FF/BV-11> <Interferer ID - 1 for CW> <For fixed freq testing note centre freq in MHz here>

! <Blocker power in dBm>,<Rx Sensitivity in dBm>

<Test Case ID RXBLR/RF/FF/BV-11> <Interferer ID - 2 for RI> <For fixed freq testing note centre freq in MHz here>

! <Blocker power in dBm>,<Rx Sensitivity in dBm>

<Test Case ID RXBLR/RF/FH/BV-11> <Interferer ID - 1 for CW>

! <Blocker power in dBm>,<Rx Sensitivity in dBm>

<Test Case ID RXBLR/RF/FH/BV-11> <Interferer ID - 2 for RI>

! <Blocker power in dBm>,<Rx Sensitivity in dBm>

<Test Case ID RXBLR/RF/FF/BV-12> <Interferer ID - 1 for CW> <For fixed freq testing note centre freq in MHz here>

! <Blocker power in dBm>,<Rx Sensitivity in dBm>

<Test Case ID RXBLR/RF/FF/BV-12> <Interferer ID - 2 for RI> <For fixed freq testing note centre freq in MHz here>

! <Blocker power in dBm>,<Rx Sensitivity in dBm>



<Test Case ID RXBLR/RF/FH/BV-12> <Interferer ID - 1 for CW>

! <Blocker power in dBm>,<Rx Sensitivity in dBm>

<Test Case ID RXBLR/RF/FH/BV-12> <Interferer ID - 2 for RI>

! <Blocker power in dBm>,<Rx Sensitivity in dBm>

<Test Case ID RXBLR/RF/FF/BV-13> <Interferer ID - 1 for CW> <For fixed freq testing note centre freq in MHz here>

! <Blocker power in dBm>,<Rx Sensitivity in dBm>

<Test Case ID RXBLR/RF/FF/BV-13> <Interferer ID - 2 for RI> <For fixed freq testing note centre freq in MHz here>

! <Blocker power in dBm>,<Rx Sensitivity in dBm>

<Test Case ID RXBLR/RF/FH/BV-13> <Interferer ID - 1 for CW>

! <Blocker power in dBm>,<Rx Sensitivity in dBm>

<Test Case ID RXBLR/RF/FH/BV-13> <Interferer ID - 2 for RI>

! <Blocker power in dBm>,<Rx Sensitivity in dBm>

<Test Case ID RXBLR/RFPHY/FF/BV-11> <Interferer ID - 1 for CW> <For fixed freq testing note centre freq in MHz here>

! <Blocker power in dBm>,<Rx Sensitivity in dBm>

<Test Case ID RXBLR/RFPHY/FF/BV-11> <Interferer ID - 2 for RI> <For fixed freq testing note centre freq in MHz here>

! <Blocker power in dBm>,<Rx Sensitivity in dBm>

<Test Case ID RXBLR/RFPHY/FH/BV-11> <Interferer ID - 1 for CW>

! <Blocker power in dBm>,<Rx Sensitivity in dBm>

<Test Case ID RXBLR/RFPHY/FH/BV-11> <Interferer ID - 2 for RI>

! <Blocker power in dBm>,<Rx Sensitivity in dBm>



<Test Case ID RXBLR/RFPHY/FF/BV-12> <Interferer ID - 1 for CW> <For fixed freq testing note centre freq in MHz here>

! <Blocker power in dBm>,<Rx Sensitivity in dBm>

<Test Case ID RXBLR/RFPHY/FF/BV-12> <Interferer ID - 2 for RI> <For fixed freq testing note centre freq in MHz here>

! <Blocker power in dBm>,<Rx Sensitivity in dBm>

<Test Case ID RXBLR/RFPHY/FH/BV-12> <Interferer ID - 1 for CW>

! <Blocker power in dBm>,<Rx Sensitivity in dBm>

<Test Case ID RXBLR/RFPHY/FH/BV-12> <Interferer ID - 2 for RI>

! <Blocker power in dBm>,<Rx Sensitivity in dBm>

<Test Case ID RXBLR/RFPHY/FF/BV-13> <Interferer ID - 1 for CW> <For fixed freq testing note centre freq in MHz here>

! <Blocker power in dBm>,<Rx Sensitivity in dBm>

<Test Case ID RXBLR/RFPHY/FF/BV-13> <Interferer ID - 2 for RI> <For fixed freq testing note centre freq in MHz here>

! <Blocker power in dBm>,<Rx Sensitivity in dBm>

<Test Case ID RXBLR/RFPHY/FH/BV-13> <Interferer ID - 1 for CW>

! <Blocker power in dBm>,<Rx Sensitivity in dBm>

<Test Case ID RXBLR/RFPHY/FH/BV-13> <Interferer ID - 2 for RI>

! <Blocker power in dBm>,<Rx Sensitivity in dBm>

!End of File



C.2 Example test data

Initial example test data for one test with the two different interferers, CW and 5 MHz RI, follows in CSV format.

```
# RXBLR.TS.p2 test data
```

```
! Comments are preceded by an exclamation mark (!).
```

```
! Text preceded by the hash symbol (#) identifies test specifics.
```

```
# <IUT Supplier Name>, <IUT>, <Applicable Performance Criteria - %PER>
```

```
Company xyZ, xyZSoundbar, 5%
```

```
# <Test Case ID RXBLR/RF/FH/BV-11> <Interferer ID - 1 for CW>
```

```
-40,-91
```

```
-39.5, -90
```

```
-38,-89
```

```
-37.5,-88
```

```
-37,-87
```

```
-34,-86
```

```
-33.75,-85
```

```
...etc.
```

```
# <Test Case ID RXBLR/RF/FH/BV-11> <Interferer ID - 2 for RI>
```

```
-40,-86
```

```
-39.5, -85.5
```

```
...etc.
```

6 Revision history and acknowledgments

Publication Number	Revision Number	Date	Comments
0	p0	2024-09-09	Initial publication of the Bluetooth SIG Receiver Blocking Resilience Test Suite.
1	p1	2024-11-22	Added supplemental reviewer feedback, including expanding the acronyms list and adding Appendix C. Prepared for p1 publication.
2	p2	2025-02-28	Corrected LE1M/LE Coded to be listed as 1 MHz bandwidth 2.4 GHz WDTs. Added a recommendation to use the revised wv-file. Added details to the “5 MHz RI (Reference Interferer), signal specifics” section regarding the wv-file and updated the list of compatible R&S signal generators. Updated Core references to include v6.0. Made clarifications in the “Measurement setup” section and in the test procedure: power levels mentioned are RMS values, and the minimum number of packets required to check for BER/PER failure when measuring its failure RMS level. Prepared for p2 publication.

Acknowledgments

Name	Company
Magnus Sommansson	Qualcomm Technologies, Inc.
John Mills	Signify Netherlands B.V.
Marnix Vlot	NXP B.V.
Steve Jones	Samsung Cambridge Solution Centre
Thomas Olsgaard	GN Hearing A/S
Bjarne Klemmensen	Demant A/S
Brian Copsey	Bluetooth SIG, Inc.
Kenton Payne	Rohde & Schwarz

